

Emergency Exit Signs

Product Overview

- Edge Lit Long Life LED's
- Maintained / Non Maintained types
- Transparent Acrylic panel with single / double side options
- Status LED indicator (Mains / battery back up)
- Wall / Ceiling mounted options
- 28 Led's (14 nos. For main's and 14 nos. For power back up)
- 230V AC / 24V DC / 12V DC power supply options
- Power back up for 6 Hrs. In emergency conditions.
- CRCA housing duly powder coated finish
- Screen printing / Engraved as per approved pictographs

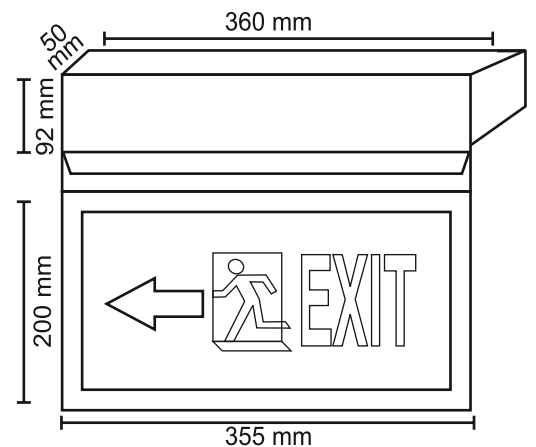

PHOTO-LUMINESCENT EXIT SIGN BOARD

Product specification- Photo-luminescent, energy saving (glow-in-dark) type Exit Sign Board. Exit sign board made on imported photo-luminescent sheet, pasted on 1mm thick aluminum sheet, monogram / signages and inscriptions made by way of computerized Vinyl Cutting and lamination.

PROHIBITION SIGNS



SAFETY SIGNS



COMBINATION SIGNS



EVACUATION PLAN

